



# AIMS POWER™

[www.aimscorp.net](http://www.aimscorp.net)

## Global LF Series Pure Sine Wave Inverter Charger User's Manual

Version 8.0

PICOGLF10W-PICOGLF60W

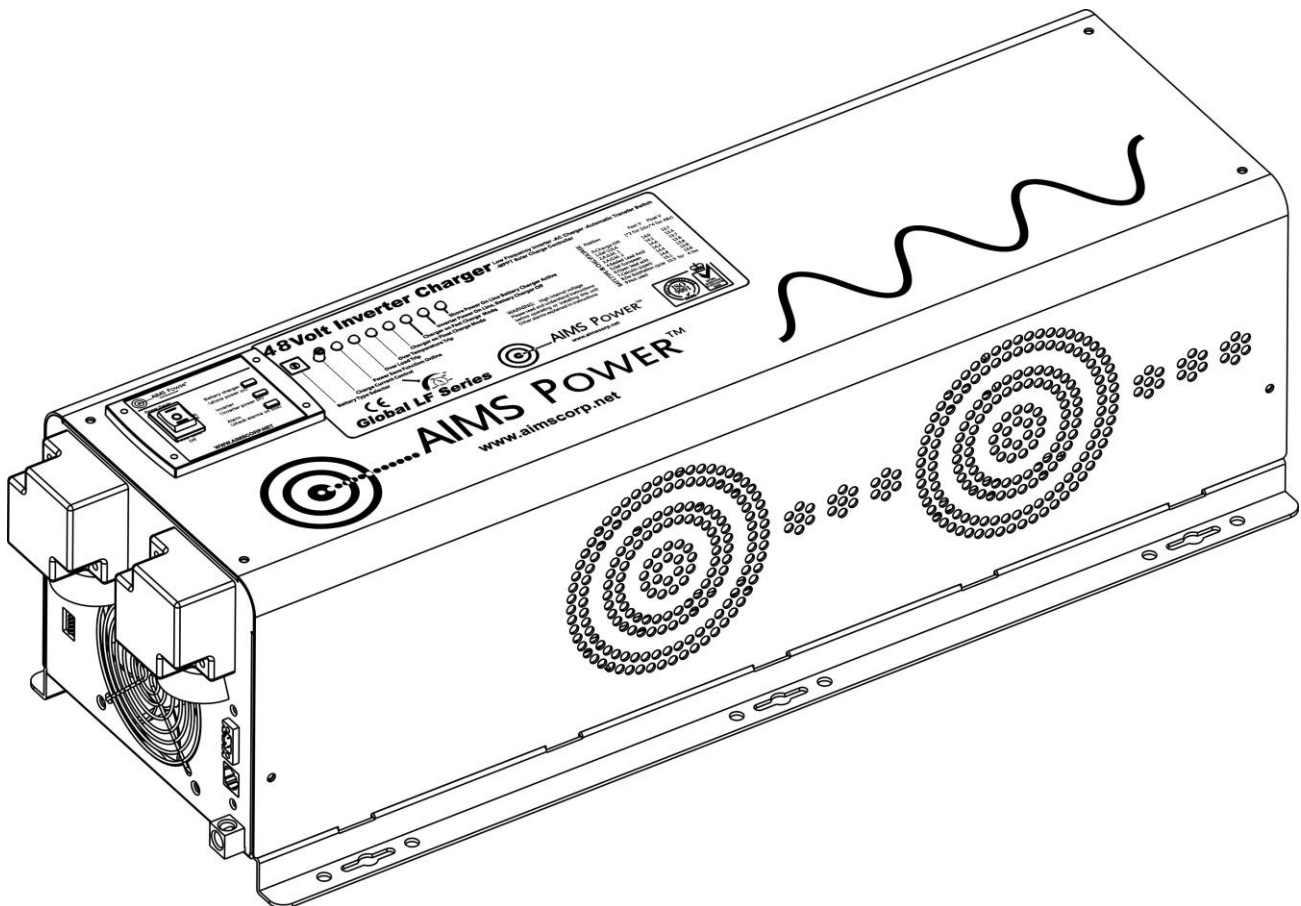



# Table of Contents

1. Important Safety Information.....	- 2 -
1-1. General Safety Precautions .....	- 2 -
1-2. Precautions When Working with Batteries .....	- 2 -
2. Introduction.....	- 3 -
2-1. General Information .....	- 3 -
2-2. Application .....	- 3 -
2-3. Mechanical Drawing .....	- 4 -
2-4. Features.....	- 6 -
2-5. Electrical Performance .....	- 6 -
2.5.1 Inverter .....	- 6 -
2.5.2 AC Charger .....	- 7 -
2.5.3 Transfer .....	- 10 -
2.5.4 Auto Frequency Adjust.....	- 10 -
2.5.5 Power Saver.....	- 10 -
2.5.6 Protections.....	- 13 -
2.5.7 Remote Control .....	- 13 -
2.5.8 LED Indicator .....	- 15 -
2.5.7 Remote Control .....	- 16 -
2.5.9 Audible Alarm .....	- 17 -
2.5.10 FAN Operation .....	- 17 -
2.5.11 DIP Switches .....	- 18 -
2.5.12 Auto Generator Start.....	- 19 -
2.5.13 Other Features .....	- 19 -
2.5.14 Automatic Voltage Regulation .....	- 20 -
3 Installation .....	- 21 -
3.1 Unpacking and Inspection .....	- 21 -
3-2. Location .....	- 22 -
3-3. DC Wiring.....	- 22 -
3-4. AC Wiring .....	- 25 -
3-5. Grounding .....	- 26 -
3.5.1 Automatic Neutral-to-Ground Connection .....	- 26 -
3.5.2 Disabling the Automatic Neutral-to-Ground Connection .....	- 27 -
3-6. Install Flange.....	- 27 -
4. Troubleshooting Guide .....	- 29 -
5. Warranty .....	- 31 -
Appendix 1 .....	- 32 -
Appendix 2 - Circuit Schematics.....	- 34 -
Appendix 3 - Installation Diagram.....	- 35 -

# 1. Important Safety Information



**WARNING!** Before using the Inverter, you need to read and save the safety instructions.

## 1-1. General Safety Precautions

1-1-1. Do not expose the Inverter to rain, snow, spray, bilge or dust. To reduce risk of hazard, do not cover or obstruct the ventilation openings. Do not install the Inverter in a zero-clearance compartment. Overheating may result. Allow at least 12" of clearance around the inverter for air flow. Make sure that the air can circulate freely around the unit. A minimum air flow of 145CFM is required.

1-1-2. To avoid risk of fire and electronic shock, make sure that existing wiring is in good electrical condition and that the wire is not undersized. Do not operate the Inverter with damaged or substandard wiring.

1-1-3. This equipment contains components which may produce arcs and/or sparks. To prevent fire and/or explosion do not install in compartments containing batteries or flammable materials or in a location which require ignition protected equipment. This includes any space containing gasoline-powered machinery, fuel tanks, or joints, fittings, or other connection between components of the fuel system.

See Warranty for instructions on obtaining service.

1-1-4. Do not disassemble the Inverter/Charger. It contains no user-serviceable parts. Attempting to service the Inverter/Charger yourself may result in electrical shock or fire. Internal capacitors remain charged after all power is disconnected.

1-1-5. To reduce the risk of electrical shock, disconnect both AC and DC power from the Inverter/Charger before attempting any maintenance or cleaning. Turning off controls will not reduce this risk

### **CAUTION: Equipment damage**

The output side of the inverter's AC wiring should at no time be connected to public power or a generator. This condition is far worse than a short circuit. If the unit survives this condition, it will shut down until corrections are made.

Installation should ensure that the inverter's AC output is, at no time, connected to its AC input.

## 1-2. Precautions When Working with Batteries

1-2-1. If battery acid contacts skin or clothing immediately wash with soap and water. If acid enters eyes immediately rinse eyes with running cold water and seek immediate medical attention.

1-2-2. Never smoke or allow a sparks or flames in the vicinity of a battery.

1-2-3. Do not drop a metal tool on the battery. The resulting spark or short-circuit on the battery will cause an explosion.

1-2-4. Remove personal metal items such as rings, bracelets, necklaces, and watches when working with a battery. A battery produces a short-circuit current high enough to weld any metal objects and will cause a severe burn.

1-2-5. To reduce the risk of injury, charge only deep-cycle lead acid, lead antimony, lead calcium gel cell, absorbed mat, LIFEPO4 lithium or NiCad/NiFe type rechargeable batteries. Other types of batteries may swell or burst causing personal injury and damage.

## 2. Introduction

### 2-1. General Information

The Global LF Series Pure Sine Wave Inverter Charger product line is a combination of an inverter and battery charger with an AC auto-transfer switch into one complete system with a peak conversion efficiency of 88%. It is packed with unique features and it is one of the most advanced inverter chargers on the market today. It features power factor correction, sophisticated multi-stage charging and pure sine wave output with unprecedentedly high surge capability to meet demanding power needs of inductive loads without damaging the equipment.

When utility AC power cuts off (or falls out of acceptable range), the transfer relay is de-energized and the load is automatically transferred to Inverter mode. Once the qualified AC power is restored the relay is re-energized and the load is automatically reconnected to AC bypass mode. The Global LF Series Inverter is equipped with a powerful four stage smart charger and includes an auto generator start feature. The overload capacity of the inverter charger products is 300% of continuous output for up to 20 seconds to reliably support tools and equipment.

Another important feature is that the inverter can be easily customized to Battery priority via a DIP switch. This helps to extract maximum power from the battery in renewable energy systems such as solar and wind. The Global LF Series Pure Sine Wave Inverter is suitable for renewable energy systems in work trucks, RV, marine and emergency appliances.

To get the most out of the power inverter, it must be operated and maintained properly. Please read the instructions in this manual before installing and operating.

### 2-2. Application

Power tools—circular saws, drills, grinders, sanders, buffers, weed and hedge trimmers, air compressors.

Office equipment – computers, printers, monitors, facsimile machines, scanners.

Household items – vacuum cleaners, fans, fluorescent and incandescent lights, shavers, sewing machines.

Kitchen appliances – coffee makers, blenders, ice makers, toasters.

Industrial equipment – metal halide lamp, high – pressure sodium lamp.

Home entertainment electronics – television, VCRs, video games, stereos, musical instruments, satellite equipment.

## 2-3. Mechanical Drawing

### PICOGLF 1-6KW Battery Side

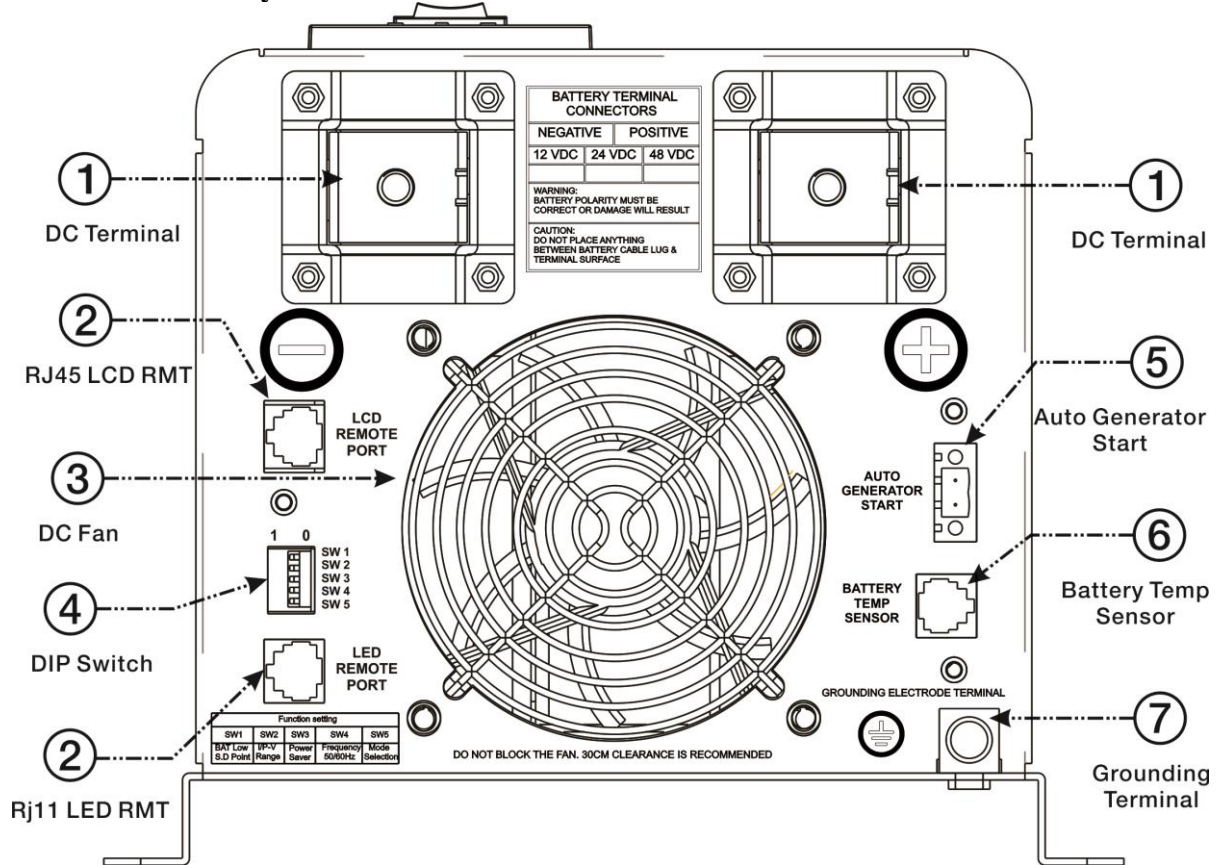

### PICOGLF 1-1.5KW AC Side

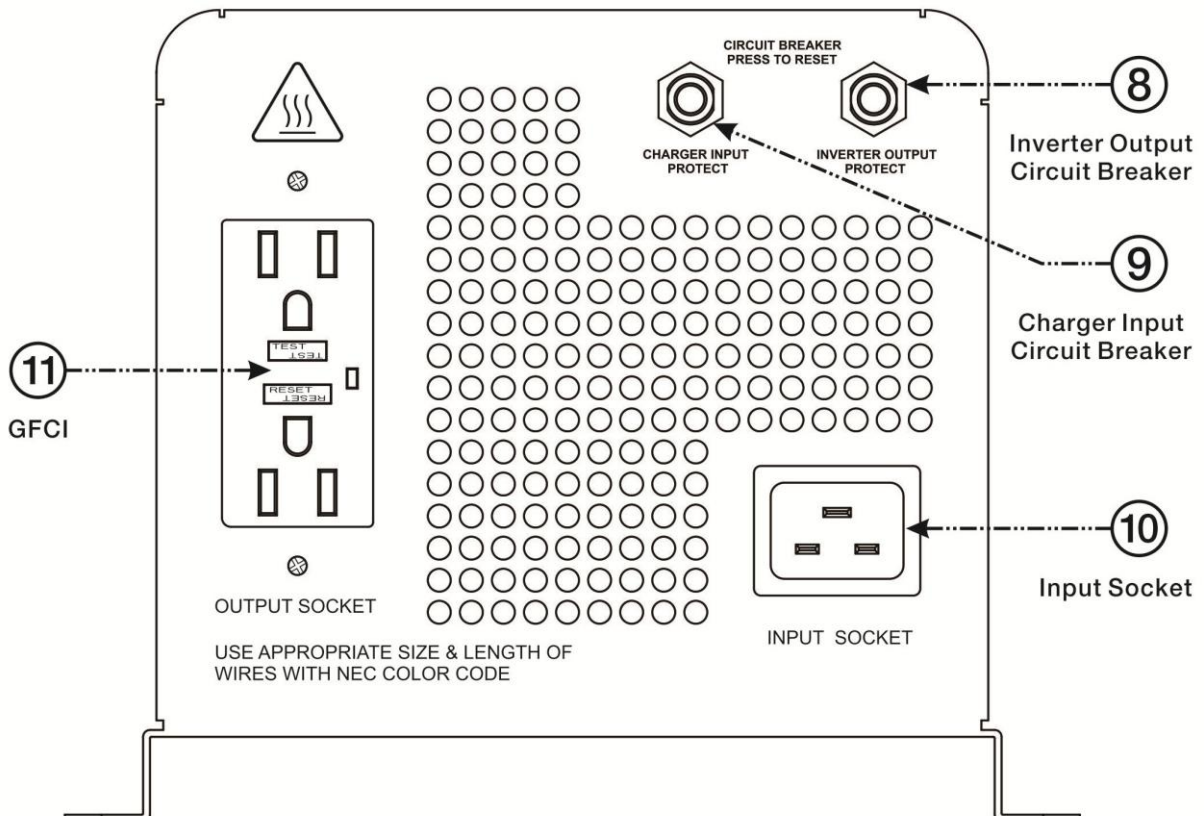



### PICOGLF 2-3KW AC Side

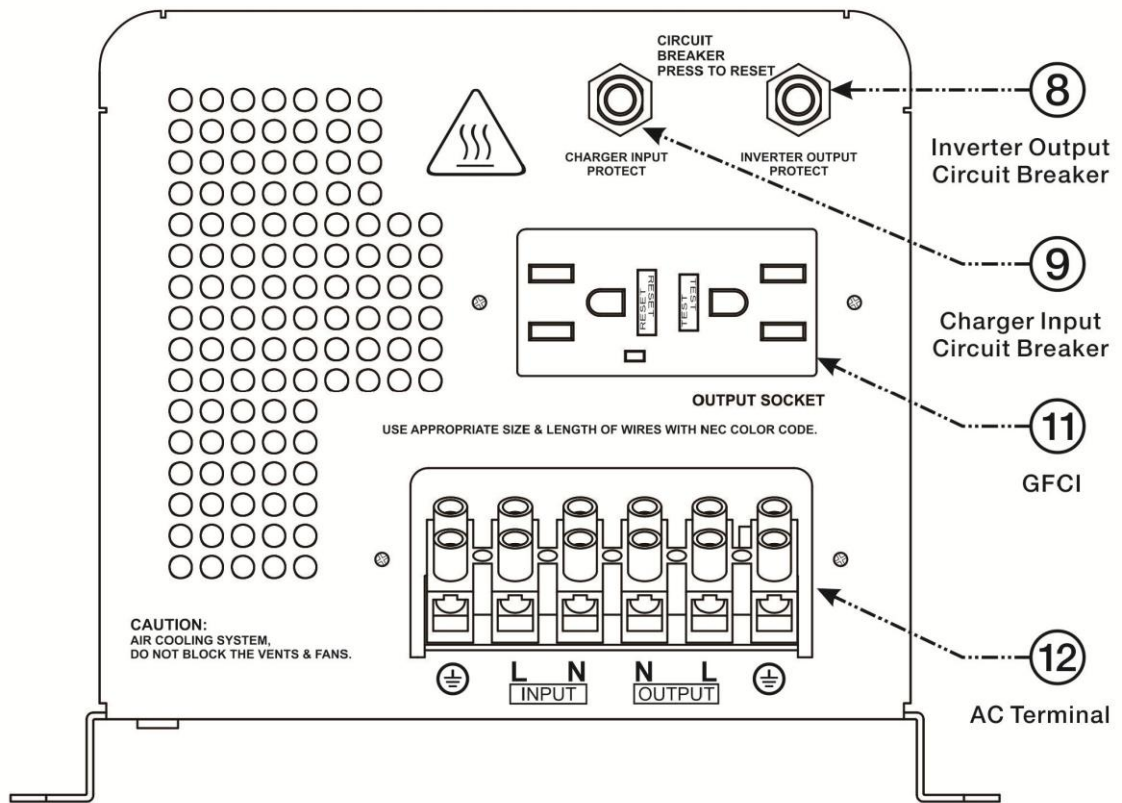

### PICOGLF 4-6KW AC Side

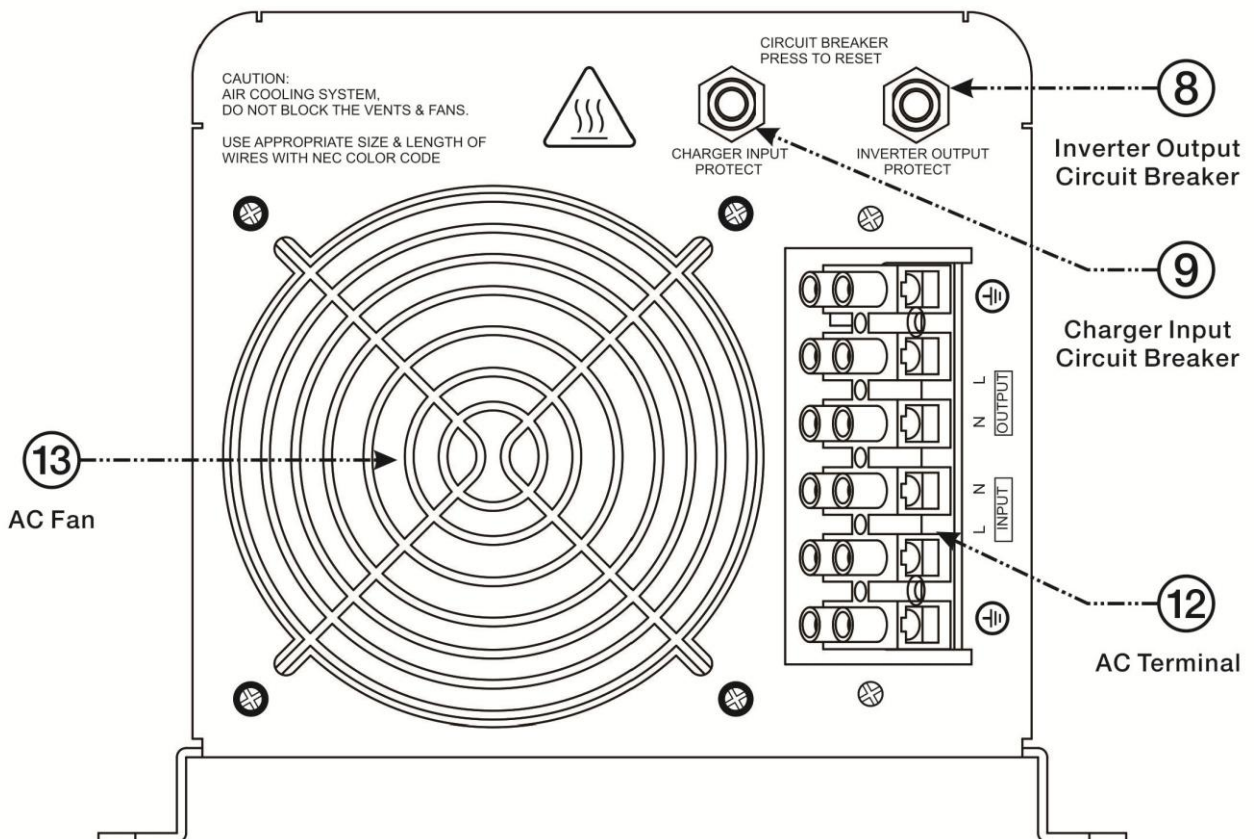

## 2-4. Features

- ⊙ High overload ability up to 300% of rated power (20 sec)
- ⊙ Low quiescent current, low power “Power Saving Mode” to conserve energy
- ⊙ Automatic Generator Start
- ⊙ 4-step intelligent battery charger, PFC (Power Factor Correction) for charger
- ⊙ 8 pre-set battery type selector switch plus de-sulphation for totally flat batteries Powerful charge rate of up to 105Amp, selectable from 0% 100%
- ⊙ 10 ms typical transfer time between battery and AC, guarantees power continuity
- ⊙ Smart LCD remote control (optional)
- ⊙ 15s delay before transfer when AC resumes, extra protection for loads when used with generator
- ⊙ Allows start up and through power with depleted batteries 30A/40A throughput current ability
- ⊙ Multiple controlled cooling fans
- ⊙ Extensive protections against various harsh situations
- ⊙ 13VDC battery recovery point, dedicated for renewable energy systems

## 2-5. Electrical Performance

### 2.5.1 Inverter

#### Topology

The Global LF inverter/charger is built according to the following topology.

Invert: Full Bridge Topology.

Charge: Isolated Boost Topology.

It works bi-directionally: in one direction it converts DC power from the battery to AC power (Inverter Mode) and in the other direction it converts external AC power to DC power to charge the batteries (AC Mode). The same power components are used in both directions, resulting in high-energy transfer efficiency with fewer components.

Please note that the inverter/charger can only work in one direction at one time (i.e. it cannot work as an inverter and as a charger at the same time).

When operating in inverter mode, the direct current (DC) that enters the inverter from the batteries is filtered by a large input capacitor and switched “On” and “Off” by the Metal Oxide Silicon Field Effect Transistors (MOSFET) at a rate of 50 Hz or 60Hz, in this step the DC is converted to low voltage synthesized sine wave AC using an H-bridge configuration and high frequency PWM (Pulse Width Modulation) technique. It is then directed into the transformer which steps the low AC voltage up to 230 or 120 volts.

The unit has a 16bit, 4.9MHZ microprocessor to control the output voltage and frequency as the DC input voltage and/or output load varies.

Because of high efficiency MOSFETs and the heavy transformers, it outputs PURE SINE WAVE AC with an average THD of 10% (min 3%, max 20% under full linear loads) depending on load connected and battery voltage. The peak DC to AC conversion efficiency of the Global LF series is >88%.



**Don't parallel the AC output of the inverters to increase power capacity as they have no stacking functionality.**

#### Overload Capacity



The Global LF series inverters have high overload capacities, making it ideal to handle demanding loads. 1 For  $110\% < \text{Load} < 125\% (\pm 10\%)$ , no audible alarm for 14 minutes, beeps 0.5s every 1s in the 15th minute, and Fault (Turn off) after the 15th minute.

2 For  $125\% < \text{Load} < 150\% (\pm 10\%)$ , beeps 0.5s every 1s and Fault (Turn off) after 1 minute. 3

For  $300\% \geq \text{Load} > 150\% (\pm 10\%)$ , beeps 0.5s every 1s and Fault (Turn off) after 20s.

### Caution:

After the inverter is switched on, it takes time for it to self-diagnose and ready to deliver full power. Hence, always switch on the load(s) after a few seconds of switching on the inverter. Avoid switching on the inverter with the load already switched on. This may prematurely trigger the overload protection. When a load is switched on, it may require an initial higher power surge to start. Hence, if multiple loads are being powered, they should be switched on one by one so that the inverter is not overloaded by the higher starting surge if all the loads are switched on at once.

## 2.5.2 AC Charger

The Global LF Series is equipped with an active PFC (Power Factor Corrected) multistage battery charger. The PFC feature is used to control the amount of power used to charge the batteries in order to obtain a power factor as close as possible to 1.

Unlike other inverters whose max charging current decreases according to the input AC voltage, Global LF series charger is able to output max current as long as the input AC voltage is in the range of 164-243VAC(95-127VAC for 120V model), and AC frequency is in the range of 48-54Hz(58-64Hz for 60Hz model).

The Global LF series inverter has a very rapid charge current available, and the max charge current can be adjusted from 0%-100% via a liner switch to the right of the battery type selector. This will be helpful if you are using our powerful charger on a small capacity battery bank. Fortunately, the liner switch can effectively reduce the max charging current to 20% of its peak.

Choosing "0" in the battery type selector will disable the charging function.



### Caution:

**Turn the charge current control switch gently to avoid breakage due to over-turning.**

There are 3 charging stages:

**Bulk Charging: (fast charge LED solid)** this is the initial stage of charging. While Bulk Charging, the charger supplies the battery with controlled constant current. The charger will remain in Bulk charge until the Absorption charge voltage (determined by the Battery Type selection) is achieved.

A software timer will measure the time from A/C start until the battery charger reaches 0.3V below the boost voltage, then take this time as  $T_0$  and  $T_0 \times 10 = T_1$ .

**Absorb Charging: (fast charge LED blinking)** This is the second charging stage when the fast charge LED is flashing and begins after the absorb voltage has been reached. Absorb Charging provides the batteries with a constant voltage and reduces the DC charging current in order to maintain the absorb voltage setting. In this period, the inverter will start a  $T_1$  timer; the charger will keep the boost voltage in Boost CV mode until the  $T_1$  timer has run out. Then drop the voltage down to the float voltage. The timer has a minimum time of 1 hour and a maximum time of 12 hours.

**Float Charging: (float charge LED solid)** The third charging stage occurs at the end of the Absorb Charging time. While Float charging, the charge voltage is reduced to the float charge voltage (determined by the Battery Type selection\*). In this stage, the batteries are kept fully charged and ready if needed by the inverter.

If the A/C is reconnected or the battery voltage drops below 12Vdc/24Vdc, the charger will restart the above cycle.

If the charge maintains the float state for 10 days, the charger will deliberately reset the cycle to protect the battery.

## Battery Charging Processes

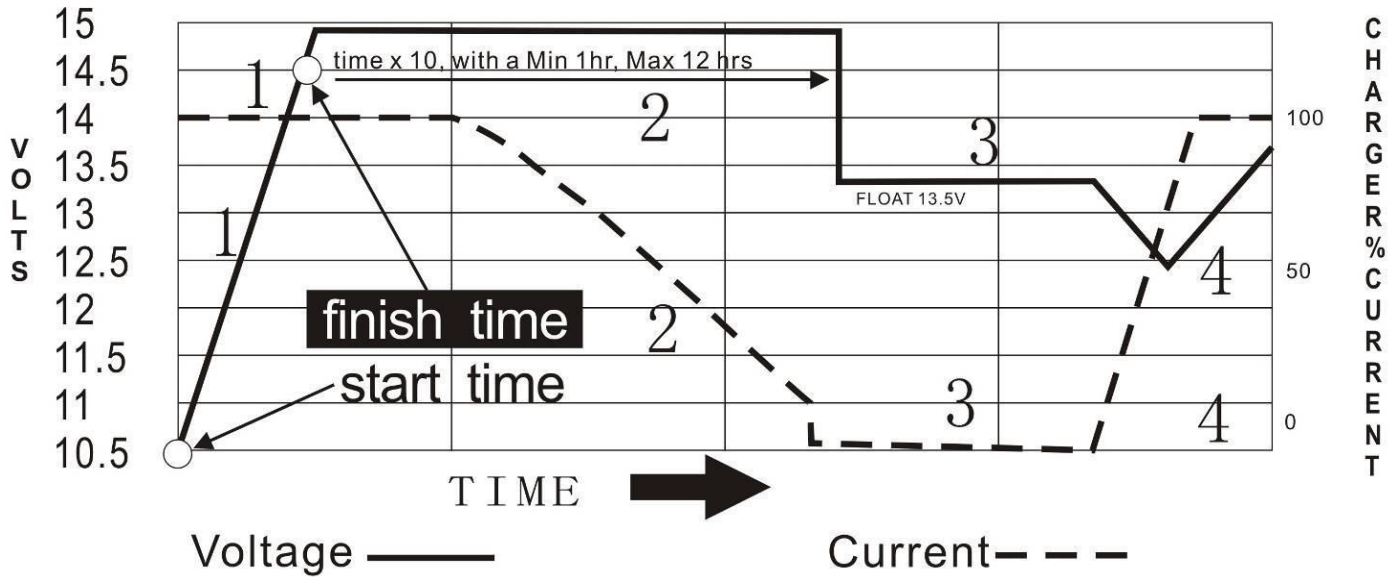

THE NEW BATTERY CHARGERS AND BOOSTERS OFFER THE FASTEST CHARGE RATE CURRENTLY AVAILABLE

STEP 1= Bulk Charge (Constant Current)  
STEP 3= Float Voltage

STEP 2 = Absorption (Constant Voltage)  
STEP 4 = RESET TO STEP 1

\*2 FOR 24 VOLTS  
\*4 FOR 48 VOLTS

ADJUSTABLE TIME DEPENDING ON BATTERY BANK CAPACITY

### Battery type selector

Switch setting	Description	Boost / Vdc	Float / Vdc
0	Charger Off		
1	Gel USA	14.0	13.7
2	AGM 1	14.1	13.4
3	AGM 2	14.6	13.7
4	Sealed lead acid	14.4	13.6
5	Gel EURO	14.4	13.8
6	Open lead acid	14.8	13.8
7	Lithium battery	14.4	14.4
8	De-sulphation	15.5 (4 Hours then Off)	
9	Not used		

For 24V X 2, for 48V X 4. (X= multiply)

### De-sulphation

The de-sulphation cycle (*switch position 8*) is a very dangerous setting if you do not know what you are doing. Before attempting to use this cycle you must clearly understand what it does and when and how you would use it.

What causes sulphation? This can occur with infrequent use of the batteries or if the batteries have been discharged low enough that they will not accept a charge. This cycle is a very high voltage charge cycle designed to try to break down the sulphated crust that is preventing the plates from taking a charge and allowing the plates to clean up and accept a charge once again.

### Charging depleted batteries

The Global LF series inverter allows start up and through power with depleted batteries.

For 12VDC models: after the battery voltage goes below 10V and the power switch is kept in the "ON" position and the inverter stays connected to the battery and the battery voltage doesn't drop below 2V, the inverter will be able to charge the battery once qualified AC inputs are present.

Before the battery voltage goes below 9VDC, the charging can be activated when the switch is turned to "OFF", then to "ON".

When the voltage goes below 9VDC, and you accidentally turn the switch to OFF or disconnect the inverter from the battery, the inverter will not be able to charge the battery once again, because the CPU loses memory during this process.

### Charging current for each model

Model	Current	Model	Current
PICOGLF10W12V230V	35+/-5A	PICOGLF10W12V120VR	35+/-5A
PICOGLF10W24V230V	20+/-5A	PICOGLF10W24V120V	15+/-5A
PICOGLF15W12V230V	50+/-5A	PICOGLF15W12V120VR	50+/-5A
PICOGLF15W24V230V	25+/-5A	PICOGLF15W24V120V	25+/-5A
PICOGLF20W12V230V	65+/-5A	PICOGLF20W12V120VR	70+/-5A
PICOGLF20W24V230V	30+/-5A	PICOGLF20W24V120VR	30+/-5A
PICOGLF20W48V230V	20+/-5A	PICOGLF20W48V120VR	20+/-5A
PICOGLF30W12V230V	85+/-5A	PICOGLF30W12V120VR	100+/-5A
PICOGLF30W24V230V	45+/-5A	PICOGLF30W24V120VR	35+/-5A
PICOGLF30W48V230V	30+/-5A	PICOGLF30W48V120V	30+/-5A
PICOGLF40W12V230V	115+/-5A	PICOGLF40W12V120V	115+/-5A
PICOGLF40W24V230V	65+/-5A	PICOGLF40W24V120V	50+/-5A
PICOGLF40W48V230V	40+/-5A	PICOGLF40W48V120V	40+/-5A
PICOGLF50W24V230V	70+/-5A	PICOGLF50W24V120V	150+/-5A
PICOGLF50W24V230VS		PGLF50W12V120240VS	75+/-5A
PICOGLF50W48V230V	50+/-5A	PGLF40W12V120240VS	60+/-5A
PICOGLF50W48V230VS		PICOGLF60W24V120V	85+/-5A
PICOGLF60W24V230V	85+/-5A		
PICOGLF60W24V230VS			
PICOGLF60W48V120V	60+/-5A		

The charging capacity will go to peak charge rate in about 3 seconds. This may cause a generator to drop frequency, making the inverter transfer to battery mode.

It is recommended to gradually put the charging load on the generator by switching the charging switch from min to max. Together with the 15s switch delay our inverter gives the generator enough time to spin up. This will depend on the size of the generator and rate of charge. As a general rule, the Bulk Charging Current should be limited to 30% of the capacity of the battery bank. Higher charging current may be used if permitted by the battery manufacturer.

 <p><b>Caution:</b></p>	<p><b>Please use a small jeweler’s style flat-head screwdriver to turn the charge current control switch gently to avoid breakage due to over-turning.</b></p> <p><b>To guarantee the best performance of AC charger when the AC input is from a generator, the standby generator should be of at least 150% higher capacity than the inverter.</b></p> <p><b>Warning! Operation with an under-rated generator or generator with unqualified wave form may cause premature failure which is not under warranty.</b></p>
--	---

### 2.5.3 Transfer

#### Swift Power Transfer

While in the Standby Mode, the AC input of the inverter is continually monitored. Whenever AC power falls below the low AC voltage trip voltage (90VAC default setting for 120VAC), the inverter automatically transfers back to the Invert Mode with minimum power interruption to your appliances - as long as the inverter is turned on. The transfer from Standby mode to Inverter mode occurs in approximately 10 milliseconds. And it is even shorter from Inverter mode to Standby mode.

This transfer time is usually fast enough to keep your equipment (including computers) powered up, thus our inverter can be used as a line interactive UPS.

#### Synchronized Power Transfer

When a load is transferred from inverter AC output to another backup AC source of power through the transfer switch, there will be a finite interruption of power to the load for the transfer to take place. A mismatch of phase and frequency of the inverter AC output and the backup AC source in transfer is likely to damage the backup AC source / a reactive load. With sophisticated circuitry design, our inverter will first lock on the frequency and phase of the input shore power/generator power and make a smooth and safe transfer at the zero voltage point to minimize the impact on the power modules.

#### Transfer Delay

There is a 15-second delay from the time the inverter senses that continuously qualified AC is present at the input terminals to when the transfer is made. This delay is built in to provide sufficient time for a generator to spin-up to a stable voltage and frequency and avoid relay chattering. The inverter will not transfer to generator until it has locked onto the generator’s output. This delay is also designed to avoid frequent switching when input utility is unstable.

### 2.5.4 Auto Frequency Adjust

The factory default configuration for inverters sold in American market is 60Hz.

If the output frequency needs to be changed this is done by putting in a valid input Power Source to the inverter’s input lines. Once the inverter validates the input, the output will automatically change.

NOTE: The inverter will output factory set frequency of 60Hz controlled with DIP switch #4 position.

### 2.5.5 Power Saver

There are 2 different working statuses for our Global LF inverter: “Power On” and “Power Off”.

When the power switch is in “Unit Off” position, the inverter is powered off.

When the power switch is turned to either of “Power Saver Auto” or “Power Saver Off”, the inverter is powered on.



Power saver function is designed to conserve battery power when AC power is not or rarely required by the loads.

In this mode, the inverter pulses the AC output looking for an

AC load (i.e., electrical appliance). Whenever an AC load (greater than 50 watts) is turned on, the inverter recognizes the need for power and automatically starts inverting and output goes to full voltage. When there is no load (or less than 50 watts) detected, the inverter automatically goes back into search mode to minimize energy consumption from the battery bank.

In “Power saver on” mode, the inverter will draw power mainly in sensing moments, thus the idle consumption is significantly reduced.

The inverter will detect a load for 250ms every 3 seconds (DOP switch#3 position 1).

Note: The minimum power of a load to take inverter out of sleep mode (Power Saver On) is 50 Watts.

The Global LF Series is designed with extremely low idle power consumption which is only a mere 0.8-1.8% of its rated power.



**Global LF Series Idle Power Consumption (in Watts)**

Model NO	Power Saver Off	Power Saver On (3Secs)
PICOGLF10W12V230V	12.5	7.5
PICOGLF10W12V120V	12.5	7.5
PICOGLF10W24V230V	15	8.4
PICOGLF10W24V120V	16.5	9
PICOGLF15W12V230V	12.5	7.5
PICOGLF15W12V120V	13.5	8
PICOGLF15W24V230V	15	8.4
PICOGLF15W24V120V	16.5	9
PICOGLF20W12V230V	25	11.7
PICOGLF20W12V120V	28	12.7
PICOGLF20W24V230V	24.5	11.5
PICOGLF20W24V120V	26.5	12.2
PICOGLF20W48V230V	25	11.7
PICOGLF20W48V120V	28	12.7
PICOGLF30W12V230V	50	20
PICOGLF30W12V120V	55	21.7
PICOGLF30W24V230V	38.5	16.2
PICOGLF30W24V120V	46.5	18.9
PICOGLF30W48V230V	45	18.4
PICOGLF30W48V120V	50	20
PICOGLF40W12V120V	44.5	18.2
PICOGLF40W24V230V	48	19.4
PICOGLF40W24V120V	52.5	20.9
PICOGLF40W48V230V	48	19.4
PICOGLF40W48V120V	55.5	21.9
PICOGLF50W24V230V	62.5	24.2
PICOGLF50W24V230VS		
PICOGLF50W48V230V	68.5	26.2
PICOGLF50W48V230VS		
PICOGLF60W24V230V	76.8	29
PICOGLF60W24V230VS		
PICOGLF60W48V230V	80.7	30.3
PICOGLF60W48V230VS		

When in the search sense mode, the green power LED will blink and the inverter will make a ticking sound.



At full output voltage, the green power LED will light steadily and the inverter will make a steady humming sound. When the inverter is used as an “uninterruptible” power supply the search sense mode or “Power Saver On” function should be defeated.

### **Exceptions**

Some devices when scanned by the load sensor cannot be detected. Small fluorescent lights are the most common example. (Try altering the plug polarity by turning the plug over.) Some computers and sophisticated electronics have power supplies that do not present a load until line voltage is available. When this occurs, each unit waits for the other to begin. To drive these loads either a small companion load must be used to bring the inverter out of its search mode, or the inverter may be programmed to remain at full output voltage (Power On mode).

## **2.5.6 Protections**

The Global LF series inverter is equipped with extensive protections against various harsh situations/faults. These protections include:

AC input over voltage protection/AC input low voltage protection

Low battery alarm/high battery alarm

Over temperature protection/over load protection

Short circuit protection (1s after fault)

Back feeding protection

When over temperature /over load occur, after the fault is cleared, the master switch needs to be reset to restart the inverter.

The low battery voltage trip point can be customized from a defaulted value of 10VDC to 10.5VDC thru SW1 on the DIP switch.

The inverter will go to over temp protection when the heat sink temp.  $\geq 105^{\circ}\text{C}$  ( $221^{\circ}\text{F}$ ), and go to fault (shutdown Output) after 30 seconds. The switch needs be reset to activate the inverter.

The Global LF series inverter has back feeding protection which avoids presenting an AC voltage on the AC input terminal in inverter mode.

After the reason for the fault is cleared, the inverter needs to be reset to start working.

## **2.5.7 Remote Control**

Apart from the switch panel on the front (or top) of the inverter, an extra switch panel connected to the RJ11 port at the DC side of the inverter thru a standard telephone cable can also control the operation of the inverter (sold separately Part # PICGLFREMOTE).

If an extra switch panel is connected to the inverter via “remote control port”, together with the panel on the inverter case, the two panels will be connected and operated in parallel.

Whichever first switches from “Off” to “Power saver off” or “Power saver on”, it will power the inverter on. If the commands from the two panels conflict, the inverter will operate according to the following priority: Power saver on > Power saver off > Power off

Only when both panels are turned to the “Unit Off” position, will the inverter be powered off.

The max length of the cable is 60 feet.

**The Remote LCD will display the following content:**

Function Description

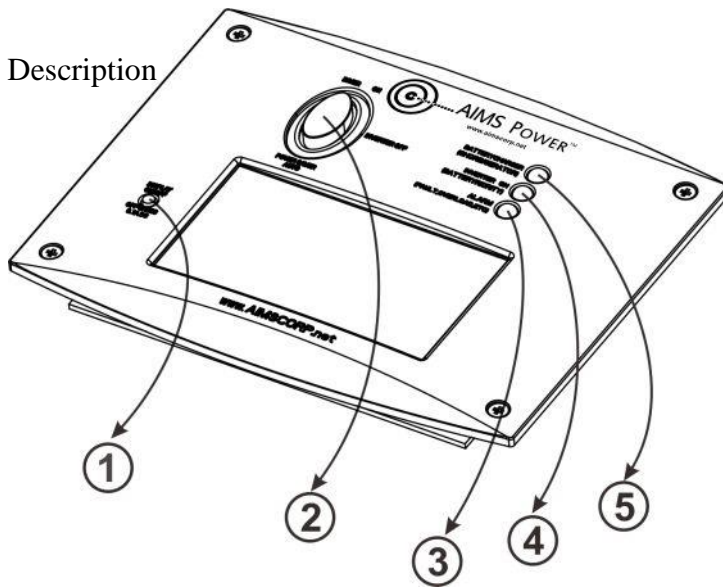

- ① Display ON&OFF
- ② Power Switch ON&OFF
- ③ Alarm LED
- ④ Inverter LED
- ⑤ Battery Charger LED

The LCD remote control panel will display the operation status of the inverter, including:

- ⊙ Input AC Voltage
- ⊙ Output AC Voltage
- ⊙ Battery Voltage
- ⊙ Output Frequency
- ⊙ Output Load
- ⊙ Work Mode
- ⊙ Alarm Fault
- ⊙ Battery Capacity

A push button on the left of the panel can be used to turn off the LCD screen and save 0.1A current draw on the battery.

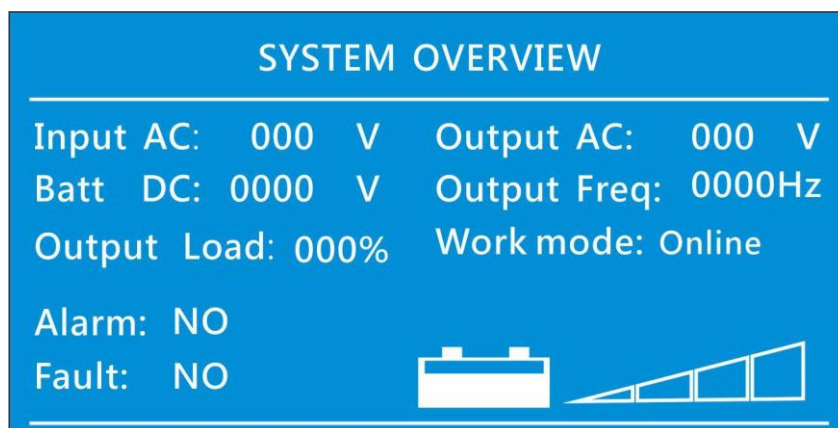

Greeting message of “Welcome to AIMS POWER”

AC Status & Input Voltage

“AC: abnormal” is displayed when AC input is not qualified.

Output Voltage/Frequency and Output Current (in percentage) in inverter mode  
Battery voltage

Note:

When the inverter is in Battery Priority mode, finishes a complete charging cycle and switches to inverter mode “AC: abnormal” will be displayed.

In AC mode, the LCD will not display the status of the AC load.



**WARNING**

Never cut the telephone cable when the cable is attached to inverter and battery is connected to the inverter. Even if the inverter is turned off, it will damage the remote PCB inside if the cable is short circuited during cutting.

**2.5.8 LED Indicator**

Function Description Drawing

## 12V Inverter & Charger

Low Frequency Inverter -AC Charger -Automatic Transfer Switch

BATT. TYPE & CHG. VOLTAGE	Position	Fast V	Float V
		(*2 for 24v; *4 for 48v)	
0.Charge Off		N/A	N/A
1.Gel U.S.A		14.0	13.7
2.A.G.M. 1		14.1	13.4
3.A.G.M. 2		14.6	13.7
4.Sealed Lead Acid		14.4	13.6
5.Gel European		14.4	13.8
6.Open Lead Acid		14.8	13.8
7.Calcium (Open)		15.1	13.6
8.De Sulphation		15.5 for 4 hrs	
9.Not Used / Customized			

**WARNING:** High internal voltage  
 Please read and understand instructions  
 before operating or installing this unit  
 Other alarms explained in instructions

Global LF Series

**AIMS POWER**<sup>TM</sup>

www.aimscorp.net

- SHORE POWER ON GREEN LED lit in AC Mode
- INVERTER ON GREEN LED lit in Inverter Mode
- FAST CHARGE Yellow LED lit in Fast Charging Mode
- FLOAT CHARGE GREEN LED lit in Float Charging Mode
- OVER TEMP TRIP RED LED lit in Over Temperature
- OVER LOAD TRIP RED LED lit in Over Load
- POWER SAVER ON GREEN LED lit in Power Saver Mode (Power Saver Load  $\leq$  25W)

## 2.5.7 Remote Control

### Status Center

<b>BATTERY TYPE</b>	<b>POWER SAVER</b>	<b>OVER LOAD</b>	<b>OVER TEMP</b>	<b>UNIT ALARM</b>	<b>FLOAT CHG</b>	<b>FAST CHG</b>	<b>INVERTER MODE</b>	<b>LINE MODE</b>
	①	②	③	④	⑤	⑥	⑦	⑧

### LED STATUS AND FAULT

Status	L.E.D.s Function	L.E.D.s on main unit								L.E.D.s on remote					
		①	②	③	④	⑤	⑥	⑦	⑧	Alarm	①	②	③		
<b>Charge function</b>	Constant current charge								on				on		
	Constant voltage charge								flash				on		
	Float					on							on		
	Standby									on					
<b>Inverter mode</b>	Inverter on									on				on	
	Power saver on	on													
<b>Alarms</b>	Battery low voltage				on				on				beep 0.5 s every 5 s	on	on
	Battery high voltage				on				on				beep 0.5 s every 5 s	on	on
	Over load (inverter mode)		on		on				on				beep 0.5 s every 5 s	on	on
	Over temp (inverter mode)			on	on				on				beep 0.5 s every 5 s	on	on
	Over temp (line mode)			on	on	on				on			beep 0.5 s every 5 s	on	on
	Over charge				on	on				on			beep 0.5 s every 5 s	on	on
<b>Fault mode</b>	Fan lock												beep continuous		
	Battery high voltage									on			beep continuous	on	
	Inverter mode overload		on										beep continuous		
	Over temperature			on									beep continuous		

### 2.5.9 Audible Alarm

<b>Battery Voltage Low</b>	Inverter green LED lit, and the buzzer beeps 0.5s every 5s.
<b>Battery Voltage High</b>	Inverter green LED lit, and the buzzer beeps 0.5s every 1s and Fault after 60s.
<b>Invert Mode Over-Load</b>	(1)110%<load<125%(±10%), No audible alarm in 14 minutes, Beeps 0.5s every 1s in 15 <sup>th</sup> minute and Fault after 15 minutes; (2)125% <load<150%(±10%), Beeps 0.5s every 1s and Fault after 60s; (3)Load>150%(±10%), Beeps 0.5s every 1s and Fault after 20s;
<b>Over Temperature</b>	Heat sink temp. ≥105°C(221°F), Over temp red LED Lighting, beeps 0.5s every 1s;

### 2.5.10 FAN Operation

For 1-3KW models, there is one multiple controlled DC fan which starts to work according to the below logic.

For 4-6KW models, there is one multiple controlled DC fan and one AC fan. The DC fan will work in the same way as the 1-3KW models, while the AC fan will work once there is AC output from the inverter. So when the inverter is in power saver mode, the AC fan will work from time to time in response to the pulse sent by the inverter in power saver mode.

The Operation of the DC fan at the DC terminal side is controlled by the following logic:

Condition	Enter Condition	Leave condition	Speed
<b>HEAT SINK</b>	$T \leq 140^{\circ}\text{F}$	$T > 149^{\circ}\text{F}$	OFF
<b>TEMPERATURE</b>	$149^{\circ}\text{F} \leq T < 185^{\circ}\text{F}$	$T \leq 140^{\circ}\text{F}$ or $T \geq 185^{\circ}\text{F}$	50%
	$T > 185^{\circ}\text{F}$	$T \leq 176^{\circ}\text{F}$	100%
<b>CHARGER CURRENT</b>	$I \leq 15\%$	$I \geq 20\%$	OFF
	$20\% < I \leq 50\% \text{Max}$	$I \leq 15\%$ or $I > 50\% \text{Max}$	50%
	$I > 50\% \text{Max}$	$I \leq 40\% \text{Max}$	100%
<b>LOAD Percentage (INV MODE)</b>	Load < 30%	Load ≥ 30%	OFF
	$30\% \leq \text{Load} < 50\%$	Load ≤ 20% or Load ≥ 50%	50%
	Load ≥ 50%	Load ≤ 40%	100%

Allow at least 12 inches of clearance around the inverter for air flow. Make sure that the air can circulate freely around the unit.

Fan noise level <60db at a distance of 3 feet

## 2.5.11 DIP Switches

On the DC end of inverter, there are 5 DIP switches which enable users to customize the performance of the device.

Switch NO	Switch Function	Position: 0	Position: 1
SW1(Utility Priority)	Low Battery Trip Point	10.0VDC	10.5VDC
SW1(Battery Priority)		10.5VDC	11.5VDC
SW2(230V)	AC Input Range	184-253VAC	154-264VAC(40-70Hz)
SW2(120V)	AC Input Range	100-135VAC	90-135VAC(40-70Hz)
SW3	Power Save Override	Inverter Off	Saver On 3 sec
SW4	Frequency Switch	50Hz	60Hz
SW5	Battery/AC Priority	AC Priority	Battery Priority

### Low Battery Trip Volt (SW1):

Deep discharge of the lead acid battery leads to high losses in capacity and early aging. In different applications a different low voltage disconnection level is preferred. For example, for solar applications, user may intend to have less DOD to prolong the battery life cycle. While for mobile applications users may intend to have more DOD to reduce battery capacity and on-board weight.

For 12VDC models, the Low Battery Trip Volt is set at 10.0VDC by default. It can be customized to 10.5VDC using SW1. This is to prevent batteries from over-discharging while there is only a small load applied on the inverter.

multiply\*2 for 24VDC, multiply\*4 for 48VDC

### AC Input Range(SW2):

There are different acceptable AC input ranges for different kinds of loads.

For some relatively sensitive electronic devices, a narrow input range of 184-253VAC (100-135V for 120VAC model) is required to protect them.

While for some resistive loads which work in a wide voltage range, the input AC range can be customized to 154-264VAC (90-135V for 120VAC model), this helps to power loads with the most AC input power without frequent switches to the battery bank.

In order to make the inverter accept dirty power from a generator, when the SW2 is switched to position “1”, the inverter will bypass an AC input with a wider voltage and frequency (40-70Hz for 50Hz/60Hz).

Accordingly, the AC charger will also work in a wider voltage and frequency range (42-68Hz for 50Hz/60Hz).

This will avoid frequent switches between battery and generator. But some sensitive loads will suffer from the low quality power.

The pros and cons should be clearly realized.

### Power Saver Override ON/OFF (SW3):

The factory default for SW3 is Position 0. Position 1 will allow the Power Save feature of the inverter to detect a load for 250ms every 3 seconds. If a load is detected, the inverter will output AC Power. If SW3 is moved to Position 0. This will prevent the sense pulse from being sent out, even if inverter is in Power Save mode via Main Power switch. No power will be output unless Shore Power input is present. Only then will the battery charger and AC throughput operate when SW3 is in Position 0.

### Frequency Switch (SW4):

The output frequency of the inverter can be set at either 50Hz or 60Hz by SW4.

### AC/Battery Priority (SW5):



Our inverter is designed with AC priority by default. This means, when AC input is present, the battery will be charged first, and the inverter will transfer the input AC to power the load. Only when the AC input is stable for a continuous period of 15 days will the inverter start a battery inverting cycle to protect the battery. After 1 normal charging cycle ac through put will be restored.

The AC Priority and Battery Priority switch is SW4. When you choose battery priority, the inverter will invert from battery despite the AC input. Only when the battery voltage reaches the low voltage alarm point(10.5V for 12V,21Vdc for 24Vdc, 42Vdc for 48Vdc) will the inverter transfer to AC Input, charge battery, and switch back to battery when the battery is fully charged. This function is mainly for wind/solar systems using utility power as back up.

**Note: In battery priority mode, when qualified AC inputs for the first time and the battery voltage is below 12.5Vdc (12.5Vdc for 12Vdc, 25Vdc for 24Vdc, 51Vdc for 48Vdc), the inverter will go into battery priority mode only after a cycle of bulk charging and absorb charging is finished. The inverter will not go into float charging mode.**

## 2.5.12 Auto Generator Start

The inverter can start up a generator when battery voltage drops.

When the inverter goes to low battery alarm, it can send a signal to start a generator and turn the generator off after battery charging is finished.

The auto gen start feature will only work with generators that have automatic starting capability. The generator must have start and stop controls [i.e., an electric starter and electric choke (for gasoline units)], and the safety sensors to be able to start and stop automatically.

There is an open/close relay that will short circuit the positive and negative cables from a generator start control. The input DC voltage can vary, but the max current the relay can carry is 16Amp.

The Auto Generator Start terminal pins are not polarized.

In addition, these two pins can also be used as dry contacts to send out “Low Battery Voltage” signal to an external alarm device.

**Use 18 AWG speaker wire for this application.**

## 2.5.13 Other Features

### Battery Temperature Sensing

Applying the proper charge voltage is critical for achieving optimum battery performance and longevity.

The ideal charge voltage required by batteries changes with battery temperature.

The battery temperature sensor allows the charge controller to continuously adjust charge voltage based on actual battery temperature.

Temperature compensation of charge voltage assures that the battery receives the proper charge voltage as battery temperature varies.

The entire line of Global LF inverters are equipped with Battery Temperature Sensing for increased charging precision.

It sends precise information to the charger, which automatically adjusts voltage to help ensure full battery charge depending on the ambient temperature of your battery installation.

When the battery voltage is over 104°F it will reduce the charging voltage by 0.1Vdc with every degree of temperature rise.

AIMS recommends that you install Battery Temperature Sensors on all banks to protect your batteries and to provide optimal charging of each bank.

The battery temperature sensor mounts on the side of a battery using silicon or electrical tape.

The spec is listed below

Inverter Condition	Temp on BST	Operation
Charger Mode	$BTS \geq 122^{\circ}\text{F}$	Automatically turns off charger
	$BTS \leq 104^{\circ}\text{F}$	Automatically turns on charger
Inverter Mode	$104^{\circ}\text{F} \leq BTS \leq 122^{\circ}\text{F}$	Increases the low voltage shut down point by 0.5Vdc
	$BTS \geq 122^{\circ}\text{F}$	Over Temp Fault

### Battery voltage recovery start

After low battery voltage shut off (10V for 12V model or 20V for 24V model or 40V for 48V model), the inverter is able to restore operation after the battery voltage recovers to 13V/26V/52V (with power switch still in the “On” position). This function helps to save the users extra labor to reactivate the inverter when the low battery voltage returns to an acceptable range in renewable energy systems. The built in battery charger will automatically reactivate as soon as city/generator ac has been stable for 15 seconds.



### WARNING

Never leave the loads unattended, some loads (like a heater) may cause accidents in such cases. It is better to shut everything off after low voltage trip than to leave your load on, due to the risk of fire.

### Conformal Coating

AIMS Power entire line of Global LF inverters have been processed with a conformal coating on the PCB, making it water, rust, and dust resistant as well as corrosion resistant.

While these units are designed to withstand corrosion from the salty air, they are not splash proof.

## 2.5.14 Automatic Voltage Regulation

The automatic voltage regulation function is for full series of APS Pure Sine Wave Inverter/ Charger except Instead of simply bypassing the input AC to power the loads, the APS series inverter stabilizes the input AC voltage to a range of 230V/120V±10%.

Connected with batteries, the APS Series inverter will function as a UPS with max transfer time of 10 ms. With all of the unique features our inverter provides, it will bring you long-term trouble free operation.

### Function Introduction

## Input Voltage Transfer Points

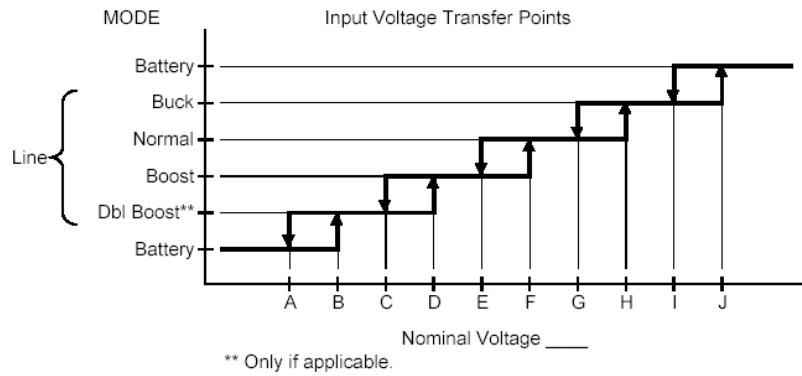

APS Function (Optional)	APS Series					
	LV (NA/JPN)			HV (INTL)		
Acceptable Input Voltage Range (Vac)	0-160			0-300		
Nominal Input Voltages (Vac)	100	110	120	220	230	240
(A) Line low loss N/W (On battery)	75/65	84/72	92/78	168/143	176/150	183/156
(B) Line Low comeback N/W (On Boost)	80/70	89/77	97/83	178/153	186/160	193/166
(C) Line 2nd boost threshold (On Boost)	**	**	**	**	**	**
(D) Line 2nd boost comeback (On Normal)	**	**	**	**	**	**
(E) Line 1st boost threshold (On Boost)	90	99	108	198	207	216
(F) Line 1st boost comeback (On Normal)	93	103	112	205	215	225
(G) Line buck comeback (On Normal)	106	118	128	235	246	256
(H) Line buck threshold (On Buck)	110	121	132	242	253	264
(I) Line high comeback (On Buck)	115	127	139	253	266	278
(J) Line high loss (On Battery)	120	132	144	263	276	288

### 3 Installation

#### 3.1 Unpacking and Inspection

Carefully remove the inverter/charger from its shipping package and inspect all contents.

Verify the following items are included:

- The PICOGLF Inverter/Charger
- Red and black DC terminal covers
- AC terminal block cover with two Phillips screws
- Two Flange nuts and 4 Phillips screws (installed on the DC terminals).
- PICOGLF Series Owner’s Manual

If items appear to be missing or damaged, contact our authorized dealer or us. If at all possible, keep your shipping box. It will help protect your inverter from damage if it ever needs to be returned for service. Save your proof-of-purchase as a record of your ownership; it will also be needed if the unit should require warranty work.

## 3-2. Location

Follow all the local regulations to install the inverter.

Install the equipment in an INDOOR location that is dry, clean, cool with good ventilation.

Working temperature: -14°F to 120°F

Storage temperature: 40°F to 158°F

Relative Humidity: 0% to 95, non-condensing

Cooling: forced air

**CAUTION:** Some models are heavy. Use proper lifting techniques during installation to prevent personal injury.



### **WARNING!**

The inverter should not be installed in an area that allows dust, fumes, insects or rodents to enter or block the inverter's ventilation openings. This area also must be free from any risk of condensation, water or any other liquid that can enter or fall on the inverter.

The entire line of inverters has been processed with a conformal coating on the PCB, making it water, rust, and dust resistant.

While these units are designed to withstand corrosion from the salty air, they are not splash proof.

The inverter's life is uncertain if used in these types of environments, and inverter failures under these conditions are not covered under warranty.

### **Installation Tools / Materials**

#### **Tools**

You will need the following tools to install the Global LF series inverters and the battery temperature sensor.

- Wire stripper
- Crimping tools for fastening lugs and terminals on DC cables
- Phillips screwdriver: #2
- Slot screwdriver (1/4" wide blade max.)
- Needle-nose pliers
- Wrench for DC terminals: 9/16"

#### **Materials**

You will need the following materials to complete your installation:

- correct size DC battery cables
- Terminals and/or crimp connectors for DC cables
- Copper wire for DC grounding: No. 8 AWG.
- Terminal or crimp connector for DC grounding cable (for 1/4" stud size)
- AC output and input wire.
- If the AC ground wire is stranded, each ground wire requires a ring terminal
- Six 1/4"-20 1.25" length steel screws or bolts to mount the inverters

## 3-3. DC Wiring

It is recommended that the battery bank be kept as close as possible to the inverter. The following is a suggested wiring option for 12 feet of DC cable.

Follow the minimum wire size. If the DC cable is longer than 12 feet, increase the size of cable to reduce voltage drop.

Power	DC Input voltage	Wire Gage
1KW	12V	AWG 1/0
1KW	24V	AWG 4
1.5KW	12V	AWG 1/0
1.5KW	24V	AWG 4
2KW	12V	AWG 1/0
2KW	24V	AWG 1/0
2KW	48V	AWG 4
3KW	12V	AWG 4/0
3KW	24V	AWG 1/0
3KW	48V	AWG 4
4KW	12V	AWG 4/0
4KW	24V	AWG 1/0
4KW	48V	AWG 1/0
5KW	24V	AWG 4/0
5KW	48V	AWG 1/0
6KW	24V	AWG 4/0
6KW	48V	AWG 1/0

Battery cables must be crimped (or preferably, soldered and crimped) copper compression lugs unless aluminum mechanical lugs are used. Soldered connections alone are not acceptable. High quality, UL-listed battery cables are available. These cables are color-coded with pressure crimped, sealed ring terminals.

Battery terminal must be clean to reduce the resistance between the DC terminal and cable connection. A buildup of dirt or oxidation may eventually lead to the cable terminal overheating during periods of high current draw. Use a stiff wire brush and remove all dirt and corrosion from the battery terminals and cables.

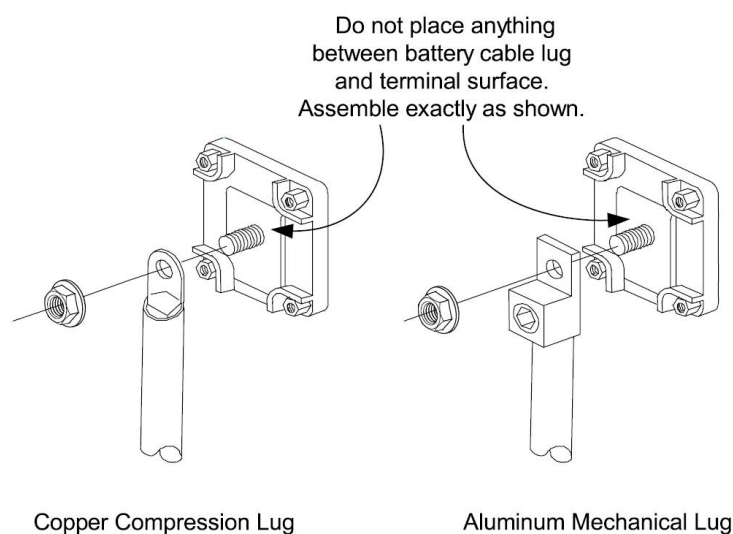

**Reducing RF interference**

To reduce the effect of radiated interference, twist the DC cables. To further reduce RF interference, shield the cables with sheathing /copper foil / braiding.

**Taping battery cables together to reduce inductance**

Do not keep the battery cables far apart. In case it is not convenient to twist the cables, keep them taped together to reduce their inductance. Reduced inductance of the battery cables helps to reduce induced voltages. This reduces ripple in the battery cables and improves performance and efficiency.

 <b>WARNING</b>	<p>The torque rating range for DC terminal is 12.5NM-20.5NM (9.25-15.19 pound-foot), and the suggested torque rating is 17NM (12.6 pound-foot). Over torqueing may break the bolt.</p>
	<p><b>Equipment Damage</b>                  The inverter is not reverse polarity protected. Reversing the battery polarity on the DC input connections will cause permanent damage to the inverter which is not covered under warranty. Always check polarity before making connections to the inverter.</p>
	<p>The inverter contains capacitors that may produce a spark when first connected to battery. Do not mount in a confined compartment with vented battery or gases.</p>
	<p>Ensure the inverter is off before disconnecting the battery cables, and that AC power is disconnected from the inverter input.</p>

 **WARNING**

Do not reverse the polarity! This can totally destroy the unit and warranty voided.



### 3-4. AC Wiring

The AC terminal is rated for wires of 8 AWG to 20 AWG, we recommend using 10 to 8 AWG wire to connect to the ac terminal block.

When in AC mode the AC input power will supply both the loads and AC charger, a thicker wire gauge for AC input is required. Please consult a qualified electrician about the specific wire gauge required in terms of wire material and inverter power.

There are 3 different ways of connecting to the terminal block depending on the model. All the wirings are CE compliant, call our tech support if you are not sure about how to wire any part of your inverter.

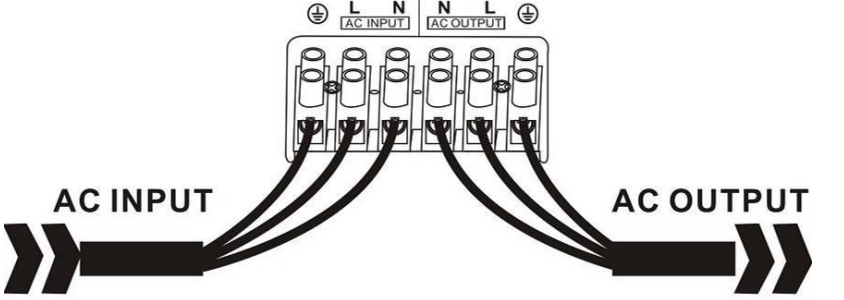
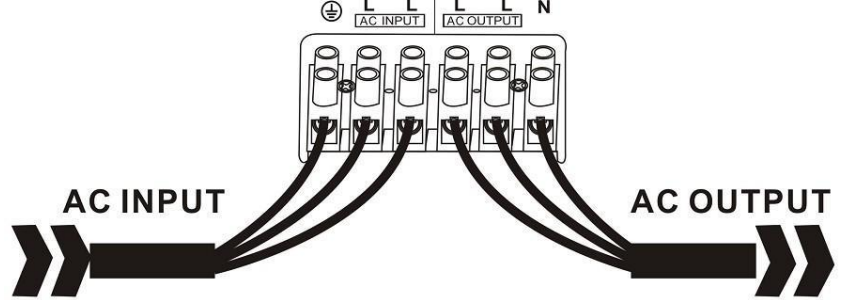
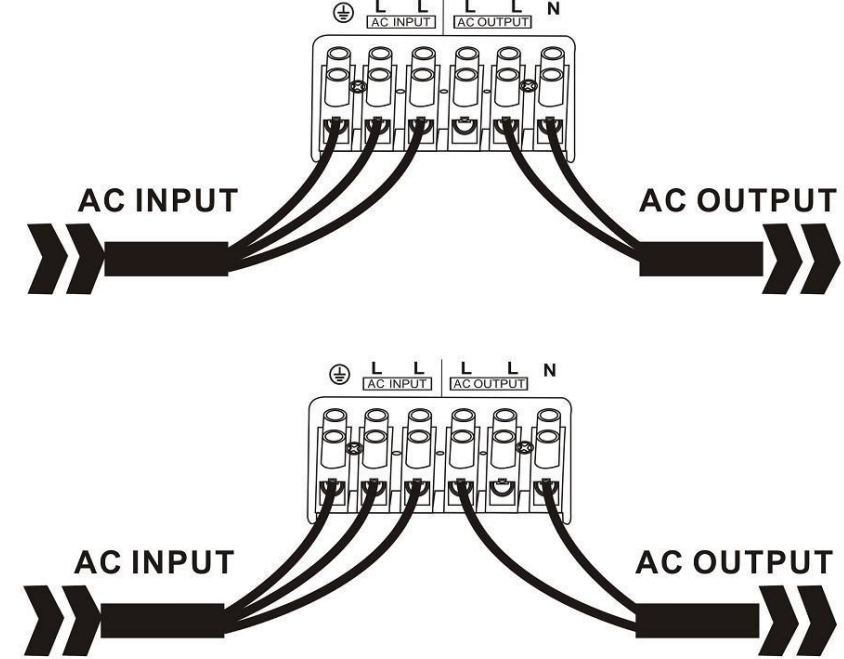
<p><b>Wiring Option 1</b></p> <p>230V single phase/120V single phase</p> <p>Input: Hot line+Neutral+Ground Output: Hot line+Neutral+Ground</p>	
<p><b>Wiring Option 2</b></p> <p>230V split phase</p> <p>Input: Hot line+ Hot line +Ground Output: Hot line+ Hot line +Neutral</p>	
<p><b>Wiring Option 3</b></p> <p>230V split phase</p> <p>Input: Hot line+ Hot line +Ground Output: Hot line +Neutral</p> <p>Remark: In such case, each output hotline can only carry a max of half the rated capacity.</p>	

 **Caution:**

Wiring Option 2 and Wiring Option 3 are only allowed for the following models:  
**PICOGLF50W24V230VS, PICOGLF50W48V230VS, PICOGLF60W24V230VS,  
 PICOGLF60W48V230VS.**

Please wire all the other models according to Wiring Option 1.

 **WARNING**

For split phase models, AC input neutral is not required in wiring. **Never Connect Input Neutral to Output Neutral. Damage will result which is not covered under warranty.**  
 Always switch on the inverter before plugging in any appliance.

 **WARNING**

The output voltage of this unit must never be connected in its input AC terminal, overload or damage may result.  
 Always switch on the inverter before plugging in any appliance.

**3-5. Grounding**

Connect an AWG 8 gauge or greater copper wire between the grounding terminal on the inverter and the earth grounding system or the vehicle chassis.

**3.5.1 Automatic Neutral-to-Ground Connection**

All single phase 120Vac inverters are equipped with automatic neutral-to-ground switching. These inverters use an internal relay that automatically connects the AC neutral output to the vehicle/boat’s safety ground (“bonding” it) in Inverter Mode and disconnects it (“un-bonding” it) when they have connected to a qualified external AC source.

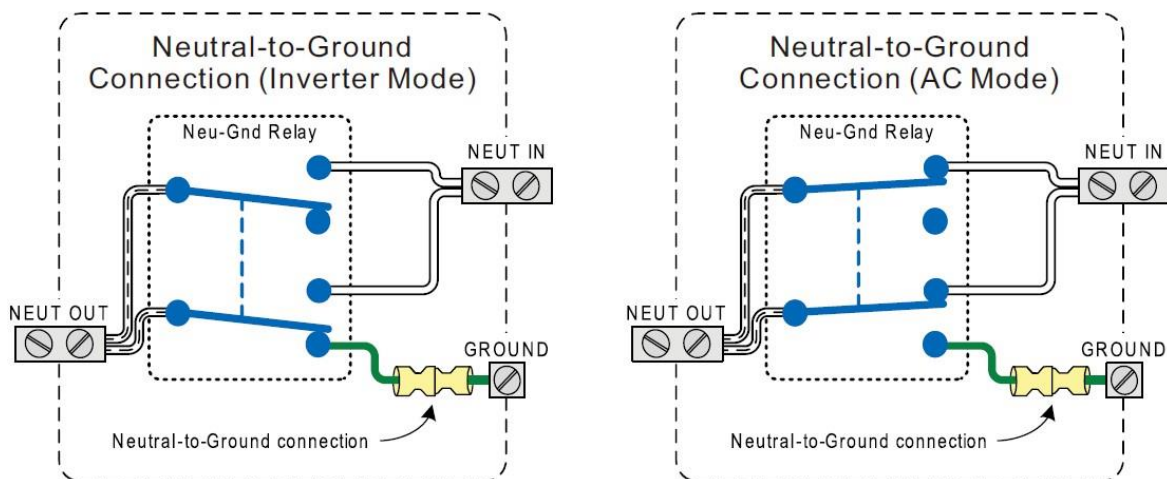

This design avoids two neutral-to-ground connections from existing at the same time, thereby preventing an electrical shock hazard between the vehicle/boat’s neutral and the external AC source’s neutral.

### 3.5.2 Disabling the Automatic Neutral-to-Ground Connection

In some installations, this feature must be disabled.

To accommodate these situations, the automatic Neutral-to-Ground Connection system can be defeated, so it will not bond the neutral in any mode of operation.

If you are not sure whether you must disable this feature, please refer to your local code requirements.

There is a section of green wire with the insulated connector at the left side of the AC terminal block. This insulated connector connects the neutral and ground inside the inverter while inverting.

Pull the two ends of the insulated connector apart to separate the green wire; this will prevent the neutral and ground from connecting inside this inverter.

If possible, use electrical tape to insulate the disconnected ends, move the two ends away from each other and push back out of the way. Typically, when connecting to a house panel (after disconnecting city power from it) is when you would disconnect this connection as a house panel already has the neutral to ground bond. In a standalone system or in a vehicle, you would want to keep this connection.

### 3-6. Install Flange

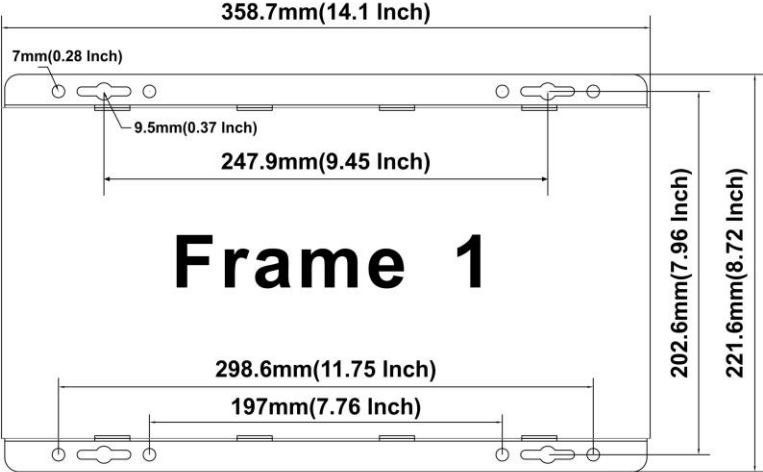
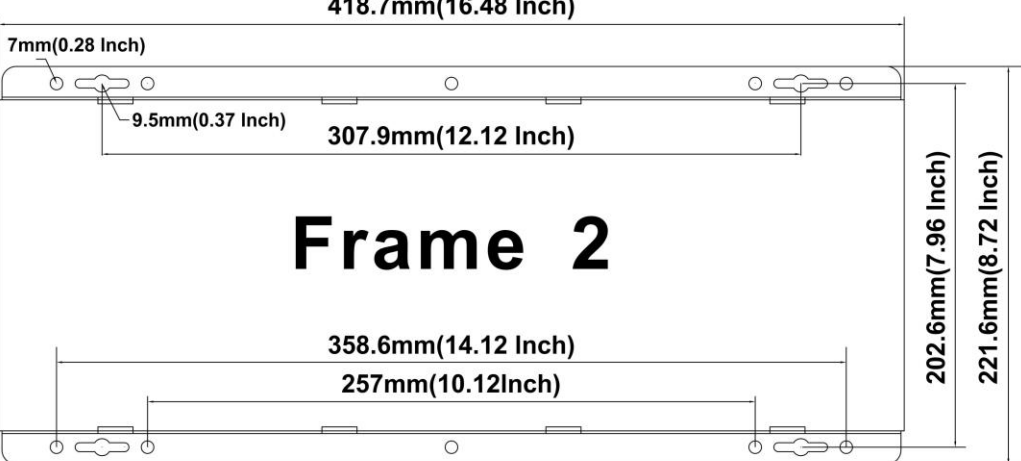
 <p style="text-align: center;"><b>Frame 1</b></p>	<p><b>1000W to 1500W Models</b></p>
 <p style="text-align: center;"><b>Frame 2</b></p>	<p><b>2000W to 3000W Models</b></p>

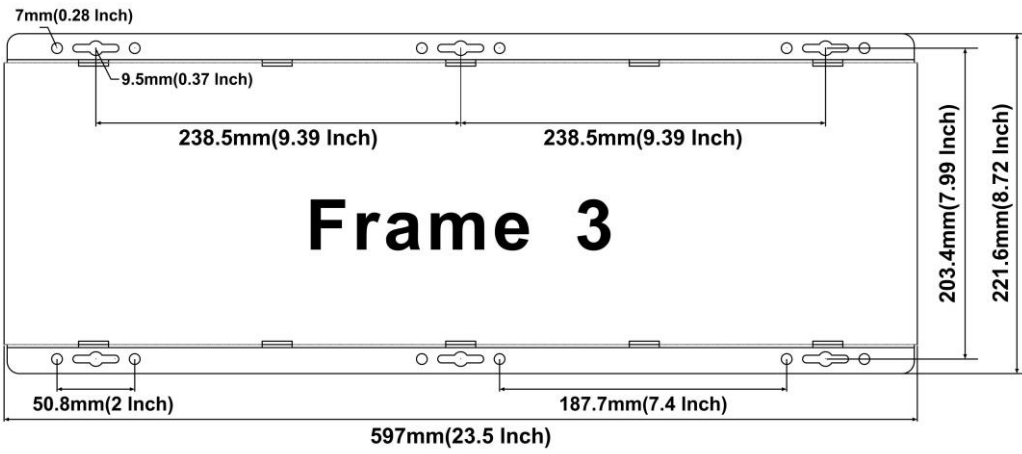

**4000W to 6000W Models**

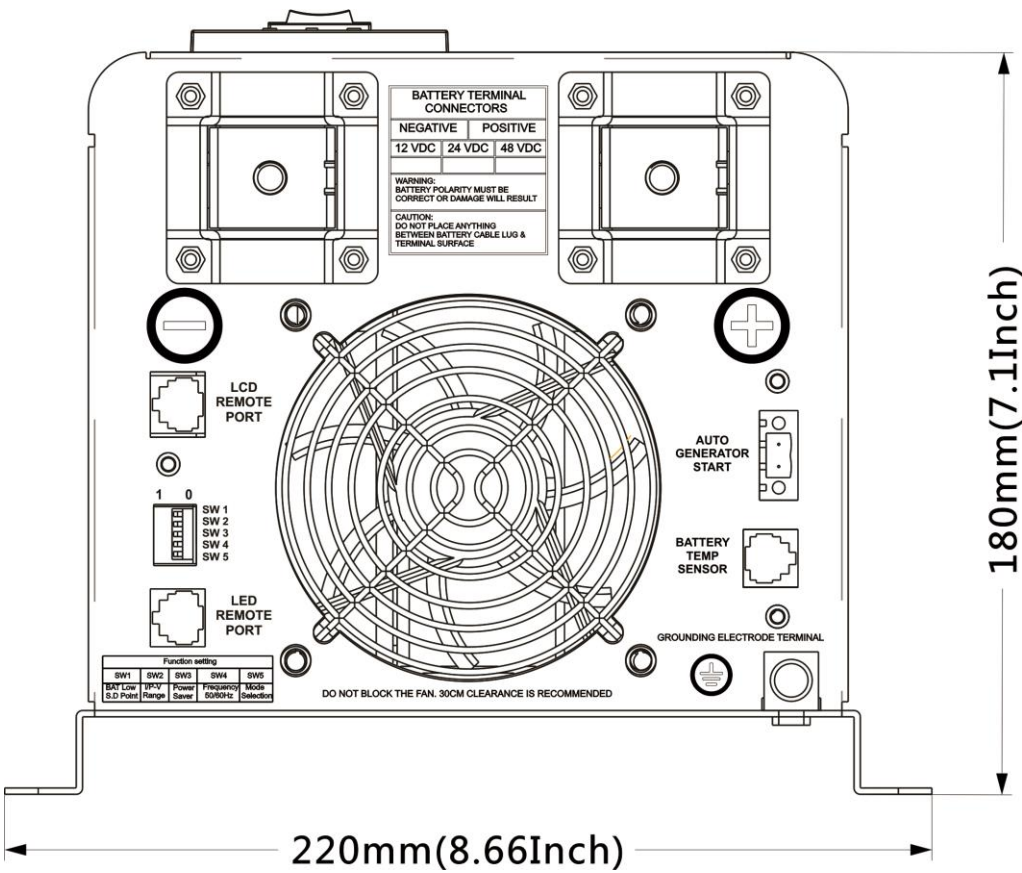

**Side View**

## 4. Troubleshooting Guide

Troubleshooting contains information about how to troubleshoot possible error conditions while using the Global LF Inverter & Charger.

The following chart is designed to help you quickly pinpoint the most common inverter failures.

### Indicator and Buzzer

Status	Item	Indicator on top cover						LED on Remote Switch				Buzzer
		SHORE POWER ON	INVERTER ON	FAST CHG	FLOAT CHG	OVER TEMP TRIP	OVER LOAD TRIP	POWER SAVER ON	BATT CHG	INVERTER	Alarm	
Line Mode	CC	√	×	√	×	×	×	×	√	×	×	×
	CV	√	×	√, blink	×	×	×	×	√	×	×	×
	Float	√	×	×	√	×	×	×	√	×	×	×
	Standby	√	×	×	×	×	×	×	×	×	×	×
Inverter Mode	Inverter On	×	√	×	×	×	×	×	×	√	×	×
	Power Saver	×	×	×	×	×	×	√	×	×	×	×
Inverter Mode	Battery Low	×	√	×	×	×	×	×	×	√	√	Beep 0.5s every 5s
	Battery High	×	√	×	×	×	×	×	×	√	√	Beep 0.5s every 1s
	Overload On Invert Mode	×	√	×	×	×	√	×	×	√	√	Refer to “Audible alarm”
	Over-Temp On Invert Mode	×	√	×	×	√	×	×	×	√	√	Beep 0.5s every 1s
	Over-Temp On Line Mode	√	×	√	×	√	×	×	√	×	√	Beep 0.5s every 1s
	Over Charge	√	×	√	×	×	×	×	√	×	√	Beep 0.5s every 1s
Fault Mode	Fan Lock	×	×	×	×	×	×	×	×	×	×	Beep continuous
	Battery High	×	√	×	×	×	×	×	×	√	×	Beep continuous
	Inverter Mode Overload	×	×	×	×	×	√	×	×	×	×	Beep continuous
	Output Short	×	×	×	×	×	√	×	×	×	√	Beep continuous
	Over-Temp	×	×	×	×	√	×	×	×	×	×	Beep continuous
	Over Charge	×	×	√	×	×	×	×	√	×	×	Beep continuous
	Back Feed Short	×	×	×	×	×	×	×	×	×	×	Beep continuous

Symptom	Possible Cause	Recommended Solution
Inverter will not turn on during initial power up.	Batteries are not connected, loose battery-side connections.  Low battery voltage.	Check the batteries and cable connections. Check DC fuse and breaker.  Charge the battery.
No AC output voltage and no indicator lights ON.	Inverter has been manually transitioned to OFF mode.	Press the switch to Power saver on or Power saver off position.
AC output voltage is low and the inverter turns loads OFF in a short time.	Low battery.	Check the condition of the batteries and recharge if possible.
Charger is inoperative and unit will not accept AC.	AC voltage has dropped out-of-tolerance	Check the AC voltage for proper voltage and frequency.
Charger is supplying a lower charge rate.	Charger controls are improperly set.  Low AC input voltage.  Loose battery or AC input connections.	Refer to the section on adjusting the “Charger Rate”.  Source qualified AC power.  Check all DC /AC connections.
Charger turns OFF while charging from a generator.	High AC input voltages from the generator.	Load the generator down with a heavy load. Turn the generator output voltage down.
Sensitive loads turn off temporarily when transferring between grid and inverting.	Inverter's Low voltage trip voltage may be too low to sustain certain loads.	Choose narrow AC voltage in the DIP switch, or Install a UPS if possible.
Noise from Transformer/case*	Applying specific loads such as hair drier	Remove the loads

**\*The reason for the noise from transformer and/or case**

When in inverter mode sometimes the transformer and/or case of the inverter may vibrate and make noise. If the noise comes from transformer:

According to the characteristics of our inverter, there is one type of load which most likely may cause rattles of transformer.

That is a half wave load: A load that uses only half a cycle of the power. This tends to cause an imbalance of the magnetic field of the transformer, reducing its rated working frequency from 20KHz to, say, maybe 15KHz (it varies according to different loads). In such a case the frequency of noise falls exactly into the range (200Hz-20KHz) that human ears can hear.

The most common load of such kind is a hair drier. If the noise comes from the case:

Normally when loaded with inductive loads, the magnetic field generated by the transformer keeps attracting or releasing the steel case at a specific frequency. This may also cause noise.

Reducing the load power or using an inverter with bigger capacity will normally solve this problem. The noise will not do any harm to the inverter or the loads.

## 5. Warranty

We offer a 1 year limited warranty.

The following cases are not covered under warranty.

1. DC reverse polarity.
2. The inverter is NOT designed with DC reverse polarity protection. A reverse polarity may severely damage the inverter.
3. Wrong AC wiring.
4. Operation in a moist environment.
5. Operating with an undersized generator or generator with unqualified wave form.

AIMS Operating Corp., Inc. dba AIMS Power Warranty Instructions:

This product is designed using the most modern digital technology and under very strict quality control and testing guide lines. If, however you feel this product is not performing as it should, please contact us:

[techsupport@aimscorp.net](mailto:techsupport@aimscorp.net) or (775)359-6703.

We will do our best to resolve your concerns. If the product needs repair or replacement, make sure to keep your receipt/invoice, as that will need to be sent back along with the package and RA# prepaid to AIMS. You have a full 1 year from date of purchase warranty.

This warranty is valid worldwide with the exception that freight and duty charges incurred outside the contiguous 48 United States will be prepaid by customer.

Except as provided above, AIMS makes no warranty of any kind, express or implied, including without limitation the implied warranties of merchantability and fitness for a particular purpose. In no event shall AIMS be liable for indirect, special or consequential damages. This warranty only applies to AIMS Power branded products. All other name brand products are warranted by and according to their respective manufacturer. Please do not attempt to return non-AIMS Power branded products to AIMS Power.

For additional products such as:

- Modified sine wave inverters
- Pure sine wave inverters
- Solar Charge Controllers
- On Grid Inverters
- Inverter Chargers and Automatic transfer switches
- Custom cut cables
- Batteries
- Solar Panels

Please visit our web site: [www.aimscorp.net](http://www.aimscorp.net)

To find out where to buy any of our products, you may also e-mail: [sales@aimscorp.net](mailto:sales@aimscorp.net) or call (775)359-6703.



## Appendix 1

Global Low Freq Series Inverter & AC Charger								
Electrical Specifications								
	Model	1KW	1.5KW	2KW	3KW	4KW	5KW	6KW
Inverter Output	Continuous Output Power	1000W	1500W	2000W	3000W	4000W	5000W	6000W
	Surge Rating(20s)	3000W	4500W	6000W	9000W	12000W	15000W	18000W
	Capable of Starting Electric Motor	1HP	1.5HP	2HP	3HP	4HP	5HP	6HP
	Output Waveform	Pure Sine wave/Same as input (Bypass mode)						
	Nominal Efficiency	>88%(Peak)						
	Line Mode Efficiency	>95%						
	Power Factor	0.9-1.0						
	Nominal Output Voltage rms	100-110-120Vac / 220-230-240Vac						
	Output Voltage Regulation	±10% RMS						
	Output Frequency	50/60Hz ±0.3Hz						
	Short Circuit Protection	Yes, Current Limit Function (Fault after 1sec)						
	Typical transfer Time	10ms(Max)						
	THD	< 10%						
DC Input	Nominal Input Voltage	12.0Vdc (*2 for 24Vdc, *4 for 48Vdc)						
	Minimum Start Voltage	10.0Vdc						
	Low Battery Alarm	10.5Vdc / 11.0Vdc						
	Low Battery Trip	10.0Vdc / 10.5Vdc						
	High Voltage Alarm & Fault	16.0Vdc						
	High DC Input Recovery	15.5Vdc						
	Low Battery voltage recover	13.0Vdc						
	Idle Consumption-Search Mode	< 50 W when Power Saver On						
Charge	Input Voltage Range	Narrow: 100~135VAC / 194~243VAC; Wide: 90~135VAC / 164~243VAC;						
	Input Frequency Range	Narrow: 47-55±0.3Hz for 50Hz, 57-65±0.3Hz for 60Hz Wide:40-70±0.3Hz for 50Hz/60Hz						
	Output Voltage	Depends on battery type						
	Charger Breaker Rating(230Vac)	10A	10A	10A	20A	20A	30A	30A
	Charger Breaker Rating(120Vac)	10A	20A	20A	30A	40A		
	Max Charge Rate	See specific charge rates in “2.5.2 AC Charger” section						
	Over Charge Protection	15.7V for 12Vdc (*2 for 24Vdc, *4 for 48Vdc)						
	Shutdown							

	Battery type	Fast Vdc				Float Vdc			
	Gel U.S.A	14.0				13.7			
	A.G.M 1	14.1				13.4			
	A.G.M 2	14.6				13.7			
	Sealed Lead Acid	14.4				13.6			
	Gel Euro	14.4				13.8			
	Open Lead Acid	14.8				13.8			
	Lithium battery	14.4				14.4			
	De-sulphation	15.5 for 4hrs							
	Remote Control	Yes. Optional							
Bypass & Protection	Input Voltage Waveform	Sine wave (Grid or Generator)							
	Nominal Voltage	120Vac				230Vac			
	Low Voltage Trip	80V/90V±4%				184V/154V±4%			
	Low Voltage re engage	90V/100V±4%				194V/164V±4%			
	High Voltage Trip	140V±4%				253V±4%			
	High Voltage re engage	135V±4%				243V±4%			
	Max Input AC Voltage	150VAC				270VAC			
	Nominal Input Frequency	50Hz or 60Hz (Auto detect)							
	Low Frequency Trip	Narrow: 47±0.3Hz for 50Hz, 57±0.3Hz for 60Hz Wide:40±0.3Hz for 50Hz/60Hz							
	Low Frequency re engage	Narrow: 48±0.3Hz for 50Hz, 58±0.3Hz for 60Hz Wide:42±0.3Hz for 50Hz/60Hz							
	High Frequency Trip	Narrow: 55±0.3Hz for 50Hz, 65±0.3Hz for 60Hz Wide: 70Hz for 50Hz/60Hz							
	High Frequency re engage	Narrow: 54±0.3Hz for 50Hz, 64±0.3Hz for 60Hz Wide: 68Hz for 50Hz/60Hz							
	Output Short circuit protection	Circuit breaker							
Bypass breaker rating (230Vac)	10A	15A	20A	30A	30A	40A	40A		
Bypass breaker rating (120Vac)	20A	20A	30A	40A	50A				
Mechanical Specification	Mounting	Wall/Ground mount							
	Inverter Dimensions(L*W*H)	15*8.5*7"			17.5*8.5*7"		23.5*8.5*7"		
	Inverter Weight	35.27lbs	37.48 lbs	44.1 lbs	52.91 lbs	77.16 lbs	97 lbs	99.21 lbs	
	Shipping Dimensions(L*W*H)	20.75*12.75*12.5"			23.5*13*12.5"		30.5*14.25*13.75"		
	Shipping Weight	39.68 lbs	41.89 lbs	48.51 lbs	57.32 lbs	81.57 lbs	101.41 lbs	103.61 lbs	
	Display	Status LEDs							
	Standard Warranty	1 Year							

※Specifications in this manual are subject to change without prior notice.

## Appendix 2 - Circuit Schematics

### Circuitry scheme for models with automatic ground to neutral connection

#### Inverter Mode

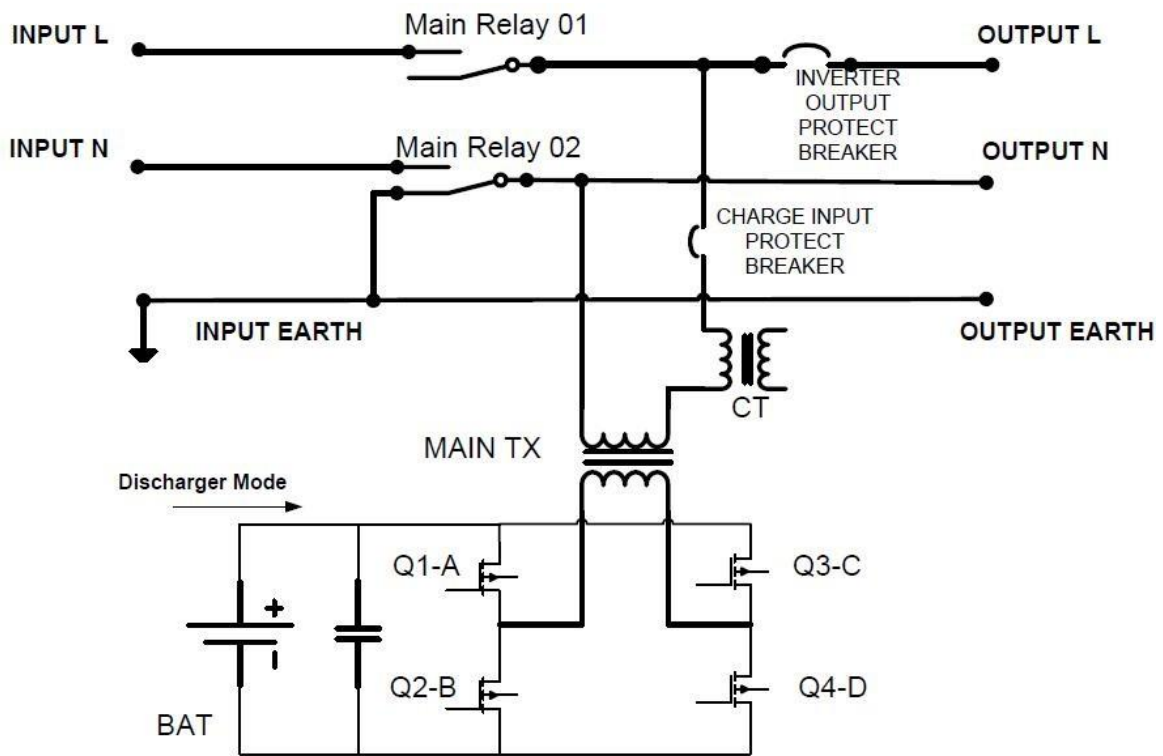

Figure 33

#### AC Mode

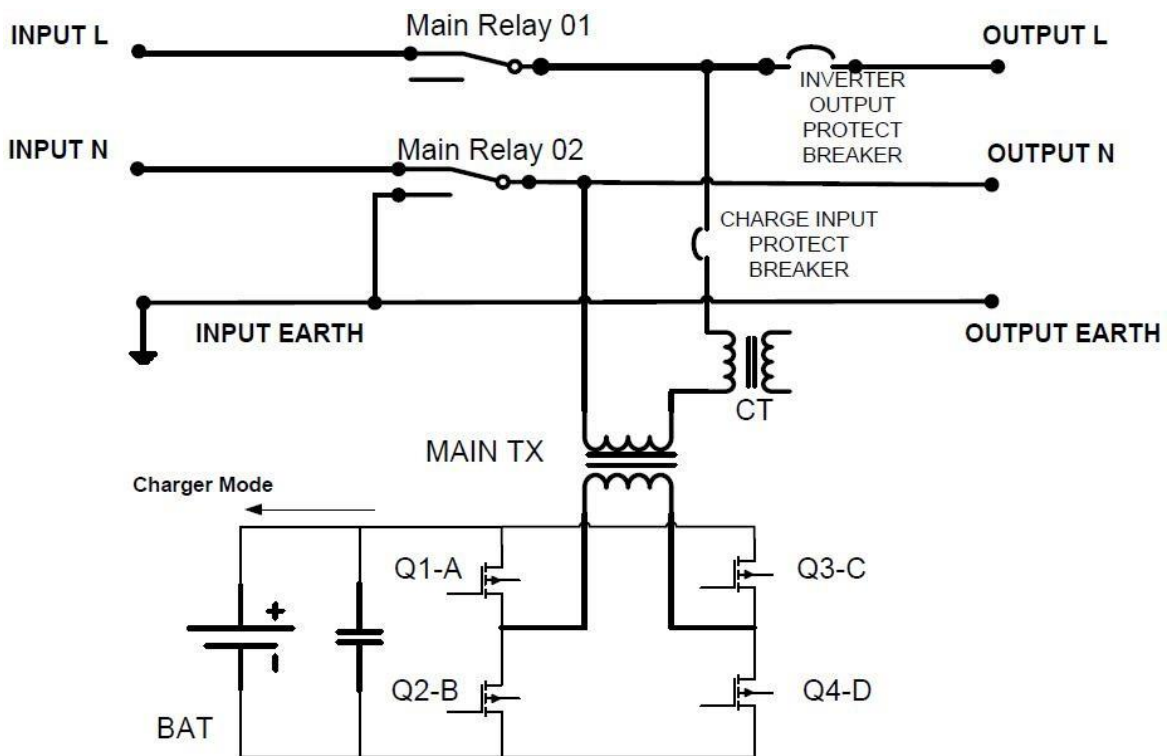

Figure 34

# Appendix 3 - Installation Diagram

\*DC shunt is not required

